

AVR900, the inventive, performing and reliable automatic pallet ring wrapper.



Packaging Systems Technology

Wrapping

AVR900, the inventive, performing and reliable automatic pallet ring wrapper

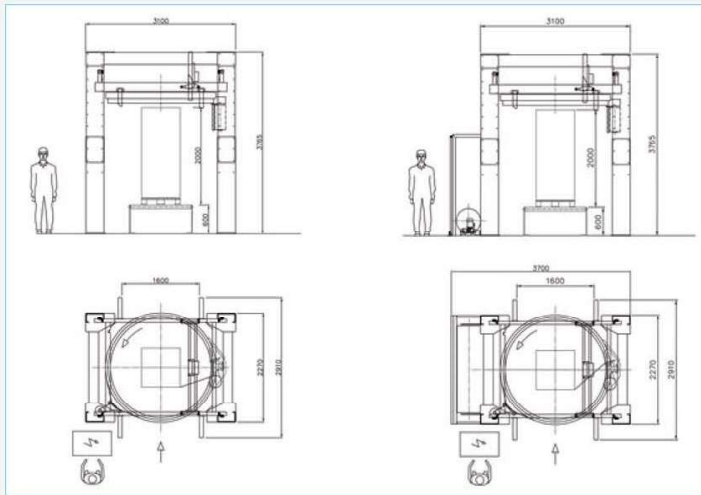

Description	Unit	Data
Rotation speed	rpm	up to 54
Production [max.]	hour	up to 100 pallets (twin: up to 140 pallets)
Minimum dimensions of the loaded pallet	mm	600 x 800
Maximum dimensions of the loaded pallet	mm	1100 x 1300
Minimum height of the loaded pallet	mm	500
Maximum height of the loaded pallet	mm	2900
Width of the stretch film roll	mm	500
Maximum diameter of the stretch film roll	mm	250
Power supply	volt	400 – 50 Hz
Control power	volt	24
Installed power	kW	5 (7 with top sheet)
Compressed air consumption	l/min	20
Compressed air pressure	bar	6 (±1)



OFFICINA MECCANICA SESTESE S.p.A.
via Borgomanero, 44-28040 Paruzzaro (No) Italy
tel. + 039 0322 541411 - Fax (039) 0322 230046

www.omsspa.com



AVR900

Why choose a ring wrapper?

- The principle of the "ring", allows to execute the wrapping cycle without any movement of the pallet load. As a consequence, the quality and the stability of the pallet load are not endangered and important production capacities remain guaranteed.
- Possibility to start and stop the wrapping cycle at any height of the pallet load, allowing specific wrapping programs, such as top wrapping and single wrapping.

A ring wrapper has a high performance rate and is flexible!

STRONG POINTS

Exclusive and patented prestretch system

This inventive and unique patented device guarantees prestretch ratio's up to 300% without any use of an additional motor or any electrical contact through slip-rings.

The results are:

- Largely increased reliability and reduced maintenance.
- Stable loads with minimal film consumption.

Exclusive and patented "tuck under" system

At the end of the cycle, the final film tail is safely inserted under the previous wrap.

The results are:

- No loose film ends, guaranteeing a perfect finishing.
- No pallet alignment needed as the system detects and moves towards the pallet.
- Reliable film end fixing without heat seal.

Simplicity and flexibility

Thanks to the particular telescopic structure, the machine is easily adjustable in height to suit the maximum pallet height of the palletized loads to be wrapped.



Wrapping speed up to 54 rotations/min.
The capacity runs up to 100 pallets/hour and 140 pallets/hour for the TWIN version.

CHOOSING AVR900 IS CHOOSING FOR:

- perfect packing of your pallet loads using very little film
- high production capacities
- simplicity and flexibility of use
- extreme robustness and increased reliability

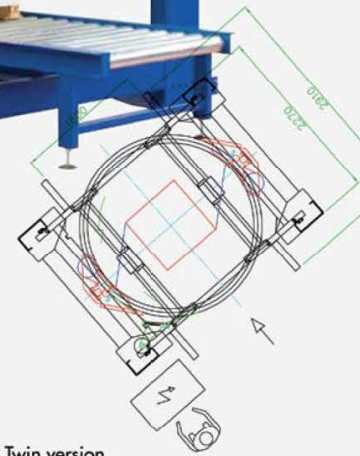

AVR900 Twin version

AVR900 with double film carriage allows capacities up to 140 pallets/hour or reduced film change interventions.



Patented "tuck under" system

Film end inserted under previous wrap. No loose film ends.



Patented prestretch system

Up to 300% prestretch with adjustable force to load. No motor, no slip-rings.

OPTIONALS



Integrated top sheet dispenser

For dustproof or waterproof pallet packaging. The top sheet roll remains at floor level thanks to film buffer system.



Top pressure plate

To hold unstable pallets and/or the top sheet during the wrapping cycle.



Corner board applicator (CBA)

This integrated applicator allows to full automatically put corner boards vertically against loads of deviant dimensions, before wrapping.

AVR900